

HC55

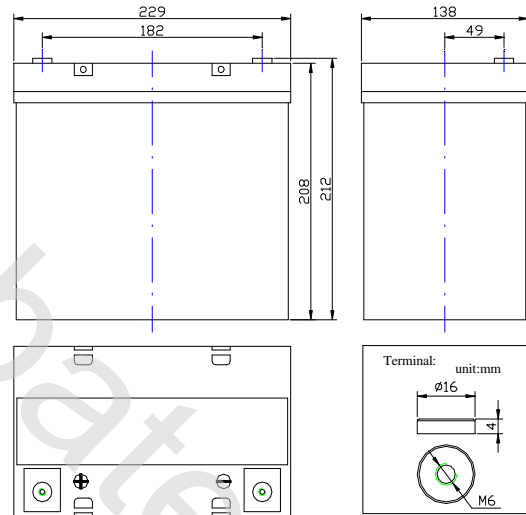

STARTING, LIGHTING & IGNITION (SLI) DRYCELL BATTERY



HC55 Specifications:

Length	229±2mm(9.02inches)
Width	138±2mm(5.43inches)
Container Height	208±2mm(8.19inches)
Total Height	212±2mm(8.35inches)
Weight	Approx 18.0Kgs(39.68 lbs)

Discharge Characteristics

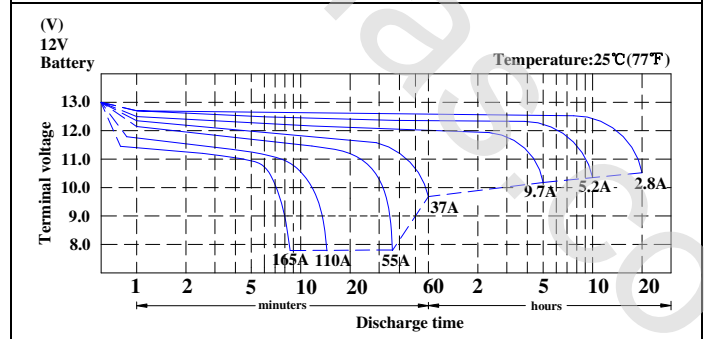

5 sec. Pulse Hot Cranking Amps (PHCA)	Capacity Minutes(25A)	Cranking Performance			5HR AH	20HR AH	Terminal
		CCA@0°F	CA@32°F	HCA@77°F			
1300A	100	620A	745A	890A	48.5	55	M6