



HC64

SPECIFICATIONS

HC series is especially used for engine starting, which requires superior cranking performance at lower temperatures, for high current discharge.

BATTERY DESIGN

- Absorbent glass mat (AGM) technology
- 12V battery VRLA
- Rugged construction
- Can be mounted in any orientation except inverted.
- US DOT and IATA certified non-spillable
- Sealed Construction (Non-Spillable Battery)
- Superior starting power
- Can be mounted inside passenger compartments
- Shipped fully charged - just install and go!

PERFORMANCE FEATURES

- PHCA: 1400A at 80°F (27°C); for 5 seconds
- PCCA: 850A at 0°F (-18°C); for 5 seconds
- CCA: 750A at 0°F (-18°C)
- CA/MCA: 900A at 32°F (0°C)
- HCA: 1080A at 80°F (27°C)
- Reserve capacity: 120 minutes
- Short circuit current: 2000A
- Operation temperature range: -5°F (-15°C) to 122°F (50°C)

Nominal Dimensions

Length		Width		Height		Total Height		Weight	
mm	in	mm	in	mm	in	mm	in	kg	pound
240.3	9.46	173.7	6.84	202	7.95	220	8.64	22.30	49.16

HIGH RATE DISCHARGE AT 77°F (25°C)

5 sec.	10 sec.	15 sec.	20 sec.
1400A	1280A	1170A	1100A

EXTENDED DISCHARGE AT 77°F (25°C) TO 10.02V

5min	15min	1hr	3hr	5hr	10hr	20hr
285A	125A	38A	17.5A	11A	6.2A	3.4A

PHYSICAL CHARACTERISTICS

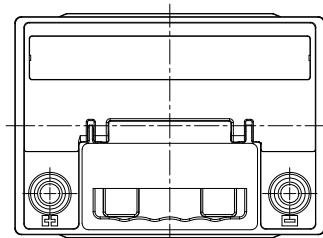
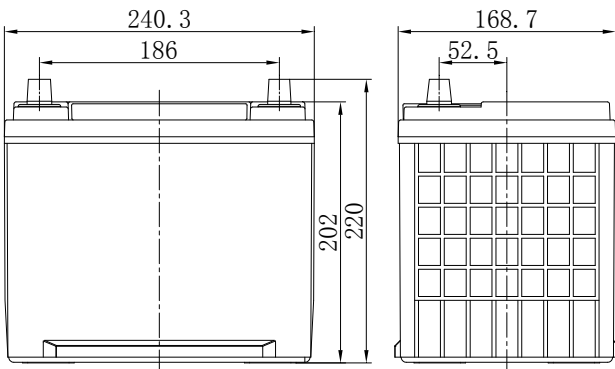

Terminal Type: AP

