



**Intec Industries Co., Ltd.**  
Room 2703, Well Tech Centre  
9 Pat Tat Street, San Po Kong, Hong Kong  
Tel : (852) 2885 1100  
Fax : (852) 2947 0588

## SPECIFICATION

<b>Type:</b>	Ni-Cd Cylindrical Cell
<b>Model No.:</b>	IPP-700AA
<b>Prepared:</b>	CYL
<b>Approved:</b>	LFX
<b>Date:</b>	Nov 30, 2010



## 1. PREFACE

This specification applies to the Intec Nickel-Cadmium Cylindrical batteries or battery packs. Intec reserves the right to alter the product design or amend this specification without prior notice.

## 2. TYPE

This specification applies to the following sealed Nickel-Cadmium battery.

Type: IPP-700AA.

Size : AA.

## 3. CHARACTERISTICS

- ★ Nominal voltage: 1.2 V
- ★ Nominal capacity: 700 mAh(0.2C/5)
- ★ Standard charge: 70 mA × 16h
- ★ Quick charge: 700 mA × 1.2h, (- Δ V = 10 mV)
- ★ Trickle charge: 23~35 mA
- ★ Discharge cut-off voltage: 1.0 V/unit(20°C)
- ★ Max current of constant discharge: 5 A (20°C, unit cell)
- ★ Operating temperature range: (Max relative humidity: 85%)
  - Standard charge +0 ~ +45°C
  - Trickle charge +10 ~ +45°C
  - Fast charge +10 ~ +45°C
  - Discharge -20 ~ +60°C
- ★ Storage temperature range: (Max relative humidity: 85%)
  - Within two years -20 ~ +30°C
  - Within two months -20 ~ +40°C
  - Within one month -20 ~ +50°C
  - Within one week -20 ~ +60°C

## 4. DIMENSION/WEIGHT

4.1. Dimensions:  $\Phi 13.8^{\pm 0.5} \times 48.0^{\pm 0.8}$  (mm);

4.2. Gross weight: 19 (g);

## 5. CELL PERFORMANCE

### 5.1. TEST REQUIREMENTS

The following conditions are for new batteries (within one month after delivery under the test method of 5.2.2).

Environmental Temperature: +15 ~ +25°C; Relative humidity: 45% ~ 85%.



**5.2. TEST METHOD AND PERFORMANCES**

**5.2.1. APPEARANCE**

The cell should be free from stretches, dents, dirt and rusts.

**5.2.2. CAPACITY**

Charge with 0.1C for 16 hours then discharge with 0.2C to the end-voltage 1.0 V/unit, the capacity shall be more than 700 mAh.

**5.2.3. OPEN-CIRCUIT VOLTAGE**

The open-circuit voltage within one hour after full charge shall be more than 1.25V/unit.

**5.2.4. INTERNAL IMPEDENCE**

Within one hour after full charge, the internal impedance shall be less than 28 mΩ /cell.

**5.2.5. HIGH RATE DISCHARGE**

The capacity shall be more than 630 mAh with the constant discharge current of 700mA to the end voltage of 1.0V/unit after the battery is fully charged.

**5.2.6. SELF-DISCHARGE**

The capacity shall be more than 490 mAh after the storage of 28 days for the fully charged battery.

**5.2.7. OVER-CHARGE I**

The battery shall not cause salting, leakage or reformation when charged at 70 mA for 48 hours and the capacity shall be more than 700 mAh.

**5.2.8. OVER DISCHARGE**

The battery shall not cause reformation when it is discharged for 24 hours with the external resistance at 0.5 Ω .

**5.2.9. LIFE-SPAN(CUSTOM)**

The capacity shall be more than 490 mAh after 500 cycles with the test conditions as follow:

**TEST CONDITION**

Cycle-th	Charge	Rest	Discharge
1	Charge at 0.1C/5 f or 16 hours	None	Discharge at 0.25C/5 for 2.33 h
2 ~ 48	Charge at 0.25C/5 for 3.17 hours	None	Discharge at 0.25C/5 for 2.33 h
49	Charge at 0.25C/5 for 3.17 hours	None	Discharge to 1.0V/unit
50	Charge at 0.1C/5 for 16 hours	1 ~ 4 hours	Discharge at 0.2C/5 to 1.0V/unit



**5.2.10. LIFE-SPAN(EXPRESS)**

The battery shall supply 490 mAh at the 400th cycle under the conditions as follows.

Charge	1C <sub>5</sub> for 72 minutes (- Δ V= <u>10</u> mV)
Discharge	1C <sub>5</sub> to 1.0V/unit

**5.2.11. STORAGE**

Within 14 days, the battery shall not cause leakage at 30-60°C with the relative humidity at 75%-85%.

**5.2.12. VIBRATION**

The battery shall not cause damage to its performances when tested with the amplitude at 4 mm (0.158 inch) and the frequency at 1000Hz.

**5.2.13. DROP TEST**

The battery shall keep normal when dropped from a height of 450 mm (17.716 inch) to the wooden board.

**5.2.14. SHORT CIRCUIT**

The fully charged battery shall not explode when shorted directly by wires.

**5.2.15. INCORRECT POLARITY CHARGE**

The battery shall not explode when charged for 5 hours with the polarity being reverse.

**5.2.16. OVER CHARGE II**

The battery shall not explode when charged at 1C for 5 hours.

**6. CAUTIONS**

- A. The end-voltage is recommended at  $1.0 \pm 0.1$  V/unit.
- B. The battery may go fail when shorted, over-charged or charged with incorrect polarity.
- C. Avoid soldering directly to the battery.
- D. Do not dispose of in fire and keep away from damage.

**7. REFERENCE**

Please refer to Intec's Customer Service if there is any question on using batteries.



**Specifications**

<b>Nominal voltage</b>		<b>1.2V</b>	
<b>Capacity (mAh)</b>		<b>C/5</b>	<b>C</b>
	<b>Nominal</b>	<b>700</b>	<b>630</b>
	<b>Typical</b>	<b>715</b>	<b>645</b>
<b>Diameter</b>		<b>0.54 ± 0.02 in 13.8 ± 0.5 mm</b>	
<b>Height</b>		<b>1.89 ± 0.03 in 48.0 ± 0.8 mm</b>	
<b>Weight</b>		<b>19g</b>	
<b>Internal impedance at 1000Hz.</b>		<b>28mΩ (After charge)</b>	
<b>Charge</b>	<b>Standard</b>	<b>70mA × 16hrs.</b>	
	<b>Fast</b>	<b>700mA × 1.2hrs. -ΔV = 10mV</b>	
	<b>Trickle</b>	<b>Max.</b>	<b>35mA</b>
		<b>Min.</b>	<b>23mA</b>
<b>Ambient temperature</b>	<b>Charge</b>	<b>Standard</b>	<b>0°C ~ 45°C</b>
		<b>Fast</b>	<b>10°C ~ 45°C</b>
	<b>Discharge</b>	<b>-20°C ~ 60°C</b>	
	<b>Storage</b>	<b>-20°C ~ 60°C</b>	

Note:

- Nominal capacity, rated at C/5, 20°C.**
- Other capacities are for reference.**
- Weight and internal impedance are for reference.**

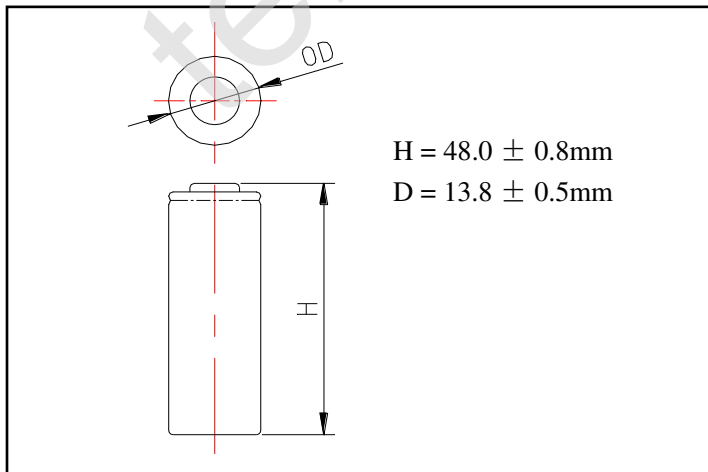

**Typical characteristics**

